

Plan Name	Wahkeena B
Date	1/7/2019
Location	Lone Oak Estates Lot 125 Battle Ground, WA

Total SqFt = 2,110

Elevations

Scale: 1/4" = 1'

This plan is property of:



© 2019 Cedar Ridge Homes
(P) 503-666-4240
(F) 503-666-2408
www.cedarridgehomes.us

Designed by:
TYSON GREY
tyson@cedarridgehomes.us

1



Front Elevation



Right Elevation



Back Elevation

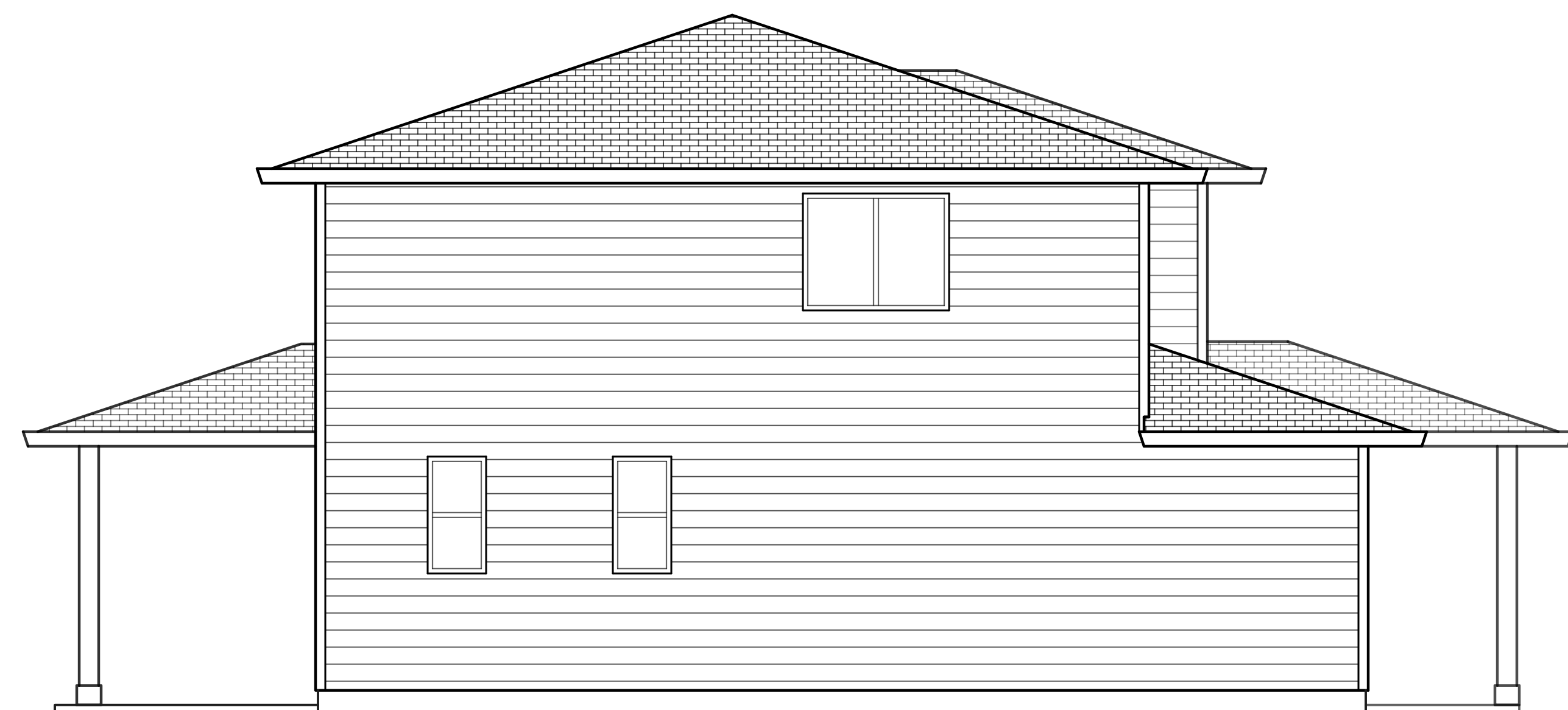

Left Elevation

Plan Name	Wahkeena B
Date	1/7/2019
Location	Lone Oak Estates Lot 125 Battle Ground, WA

Main Floor Plan

Total SqFt = 2,110
Scale: 1/4" = 1'

This plan is property of:

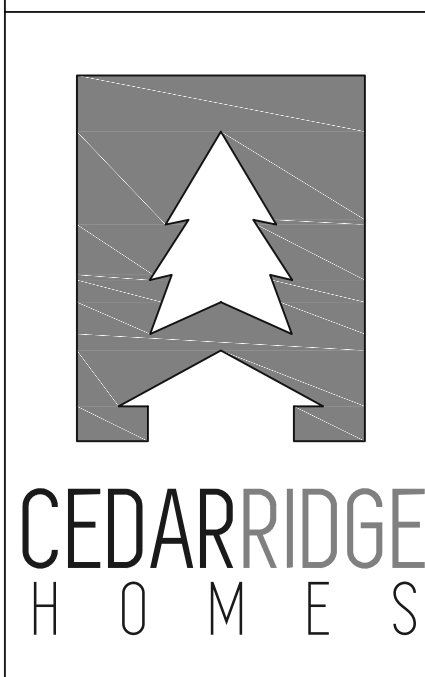

© 2019 Cedar Ridge Homes
(P) 503-666-4240
(F) 503-666-2408
www.cedarridgehomes.us

Designed by:
TYSON GREY
tyson@cedarridgehomes.us

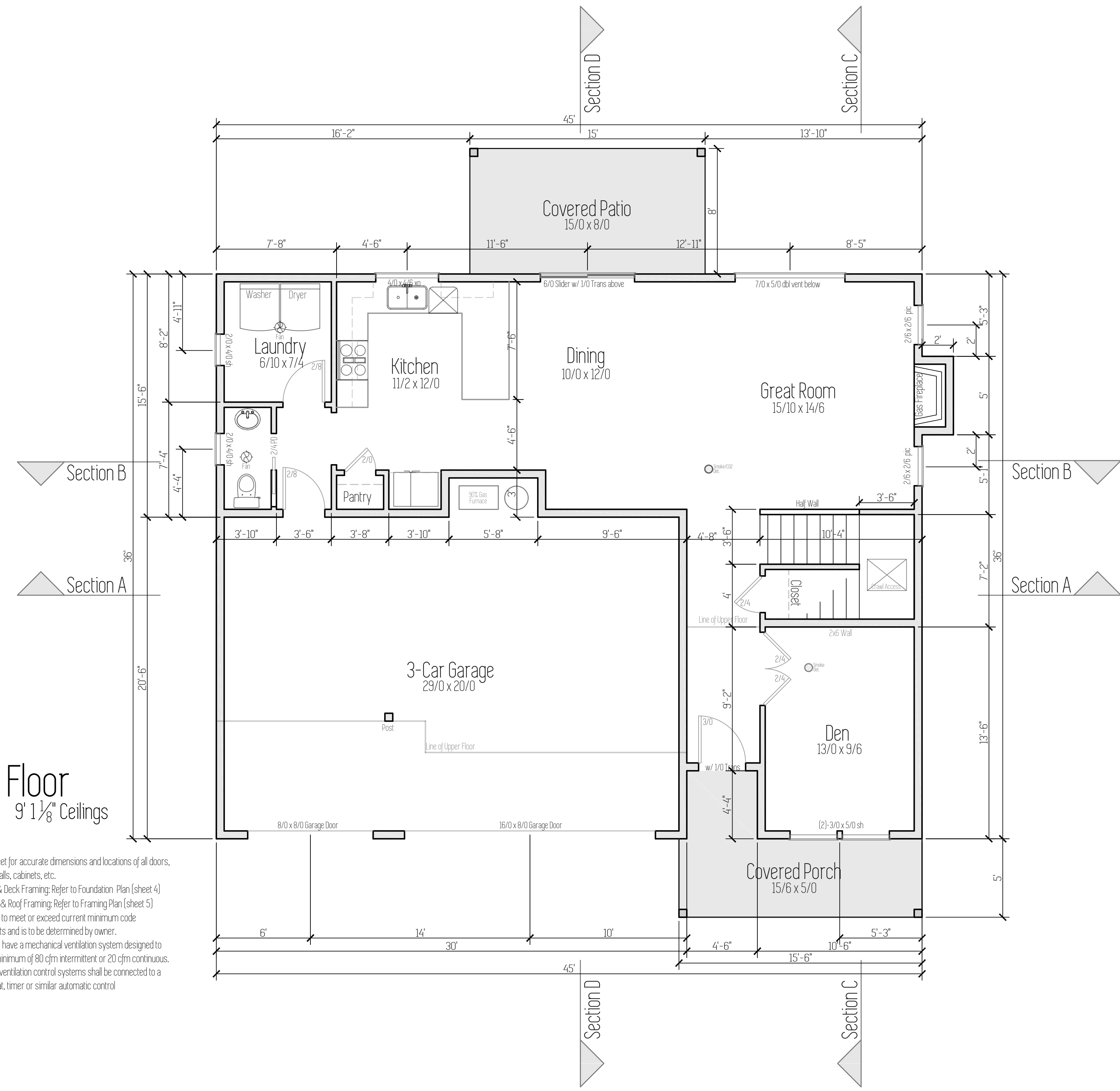

Main Floor
955 Sqft 9' 1 1/8" Ceilings

Notes

- Use this sheet for accurate dimensions and locations of all doors, windows, walls, cabinets, etc.
- Main Floor & Deck Framing: Refer to Foundation Plan (sheet 4)
- Upper Floor & Roof Framing: Refer to Framing Plan (sheet 5)
- All electrical to meet or exceed current minimum code requirements and is to be determined by owner.
- All fans shall have a mechanical ventilation system designed to exhaust a minimum of 80 cfm intermittent or 20 cfm continuous. Mechanical ventilation control systems shall be connected to a dehumidistat, timer or similar automatic control

Plan Name	Wahkeena B
Date	1/7/2019
Location	Lone Oak Estates Lot 125 Battle Ground, WA

Upper Floor Plan

Total SqFt = 2,110
Scale: 1/4" = 1'

This plan is property of:

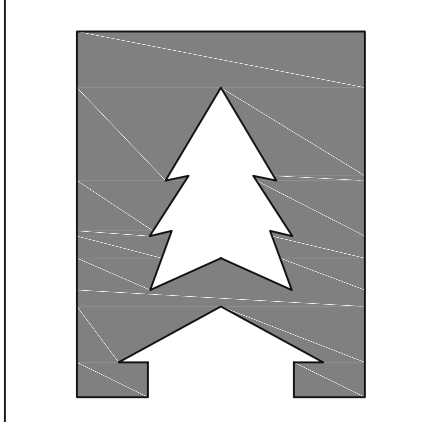

**CEDARRIDGE
H O M E S**

© 2019 Cedar Ridge Homes

(P) 503-666-4240
(F) 503-666-2408
www.cedarridgehomes.us

Designed by:

TYSON GREY
tyson@cedarridgehomes.us

3

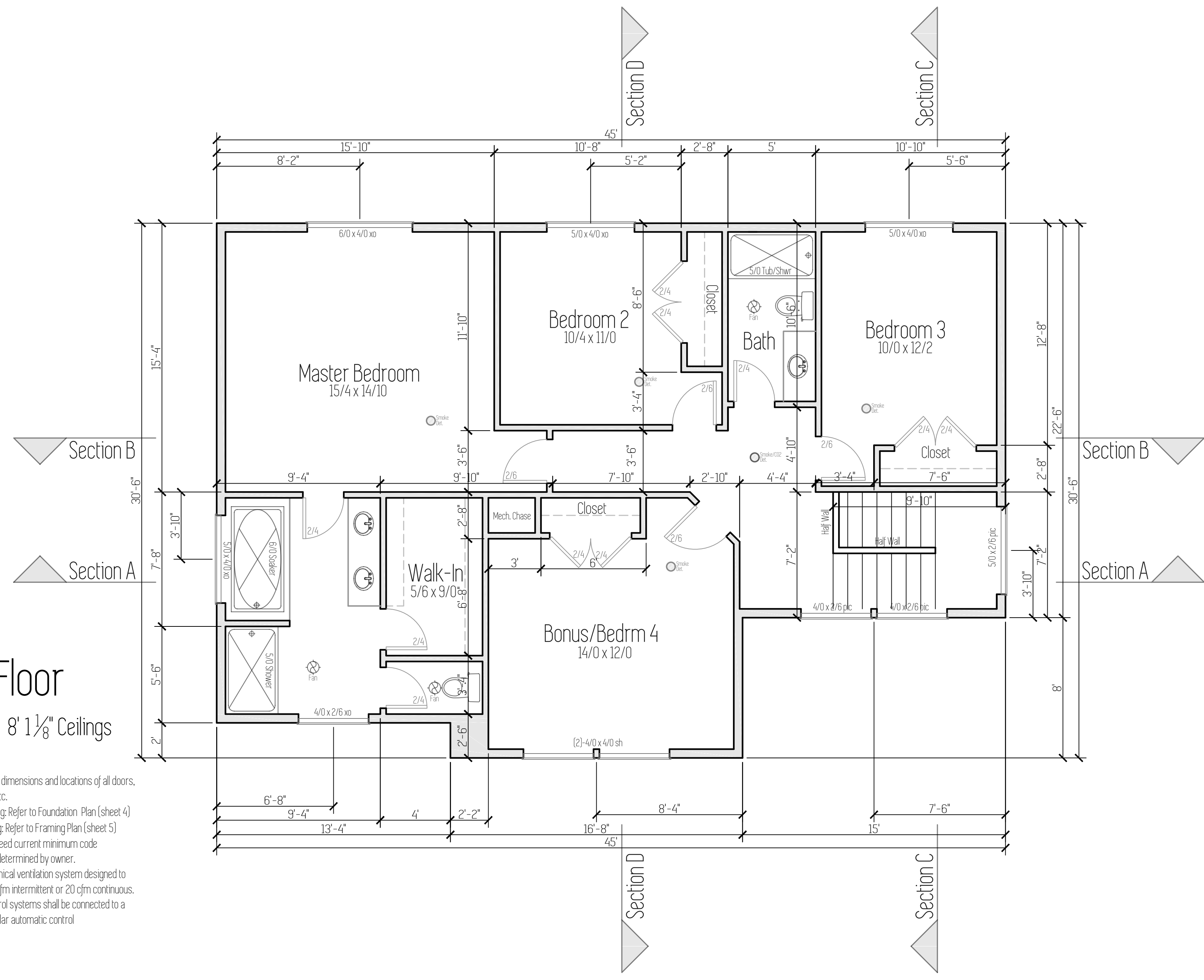

Upper Floor Notes

- 1,155 Sqft 8' 1 1/8" Ceilings
- Use this sheet for accurate dimensions and locations of all doors, windows, walls, cabinets, etc.
 - Lower Floor & Deck Framing: Refer to Foundation Plan (sheet 4)
 - Upper Floor & Roof Framing: Refer to Framing Plan (sheet 5)
 - All electrical to meet or exceed current minimum code requirements and is to be determined by owner.
 - All fans shall have a mechanical ventilation system designed to exhaust a minimum of 80 cfm intermittent or 20 cfm continuous. Mechanical ventilation control systems shall be connected to a dehumidistat, timer or similar automatic control

Plan Name	Wahkeena B
Date	1/7/2019
Location	Lone Oak Estates Lot 125 Battle Ground, WA

Foundation Plan

Total Sq Ft = 2,110
Scale: 1/4" = 1'

This plan is property of:

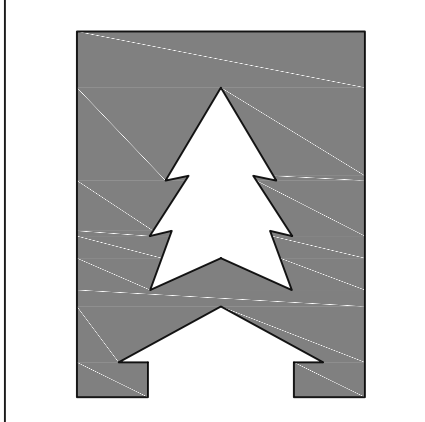

CEDARRIDGE
H O M E S

© 2019 Cedar Ridge Homes

(P) 503-666-4240
(F) 503-666-2408
www.cedarridgehomes.us

Designed by:

TYSON GREY
tyson@cedarridgehomes.us

4

Foundation Notes

- Concrete: Minimum 28 day concrete strength = 2500 psi.
- Grade beams, piers and spread footings shall be poured onto undisturbed, native soil which is free from any material that will adversely affect the soil bearing pressure.
- Footings are to be on undisturbed soil with an assumed 1500 PSF
- All slabs to be supported with a min. of 4" of compacted crushed rock fill.
- Beam pockets in concrete walls to have a min. 1/2" air space on sides, and min. 3" of bearing for all beams and girders.
- Typical pier pad to be 18" dia. x 8" concrete footing with 4x4 DF#2 post.
- Typical crawl space beam to be 4x8 DF#2. Single gusset plate to be used on both sides of attachment to post.
- Cover entire crawl space with 6 mil black visqueen vapor barrier.
- Excavate a min. of 18" below bottom of all beams.
- Install 15" x 7" closable FND vents in FND walls. Min 1 sq ft vented area for every 150 sq ft of crawl space.
- Refer to Shear Wall Schedule and Hold-Down Schedule for sill bolt spacing and hold-down size. (PAGE S1.0)

- ▨ Shear Wall Panel
- ▨ Interior Bearing Wall (above)
- HoldDown

Footing Schedule	
F1	24" x 24" x 8" Concrete footing with (2) #4 bars each way.
F2	27" x 27" x 8" Concrete footing with (2) #4 bars each way.
F7	48" x 48" x 12" Concrete footing with (6) #4 bars each way.

Radon Passive System

AF103.5.1.3 Vent Pipe
A plumbing tee or other approved connection shall be inserted horizontally beneath the sheathing and connected to a 3- or 4-inch-dia. fitting with a vertical vent pipe installed through the sheathing. The vent pipe shall be extended up through the building floors, terminate at least 12" above roof in a location at least 10' away from any window or other opening into the conditioned spaces of the building that is less than 2' below the exhaust point, and 10' from any window or other opening adjoining or adjacent buildings.

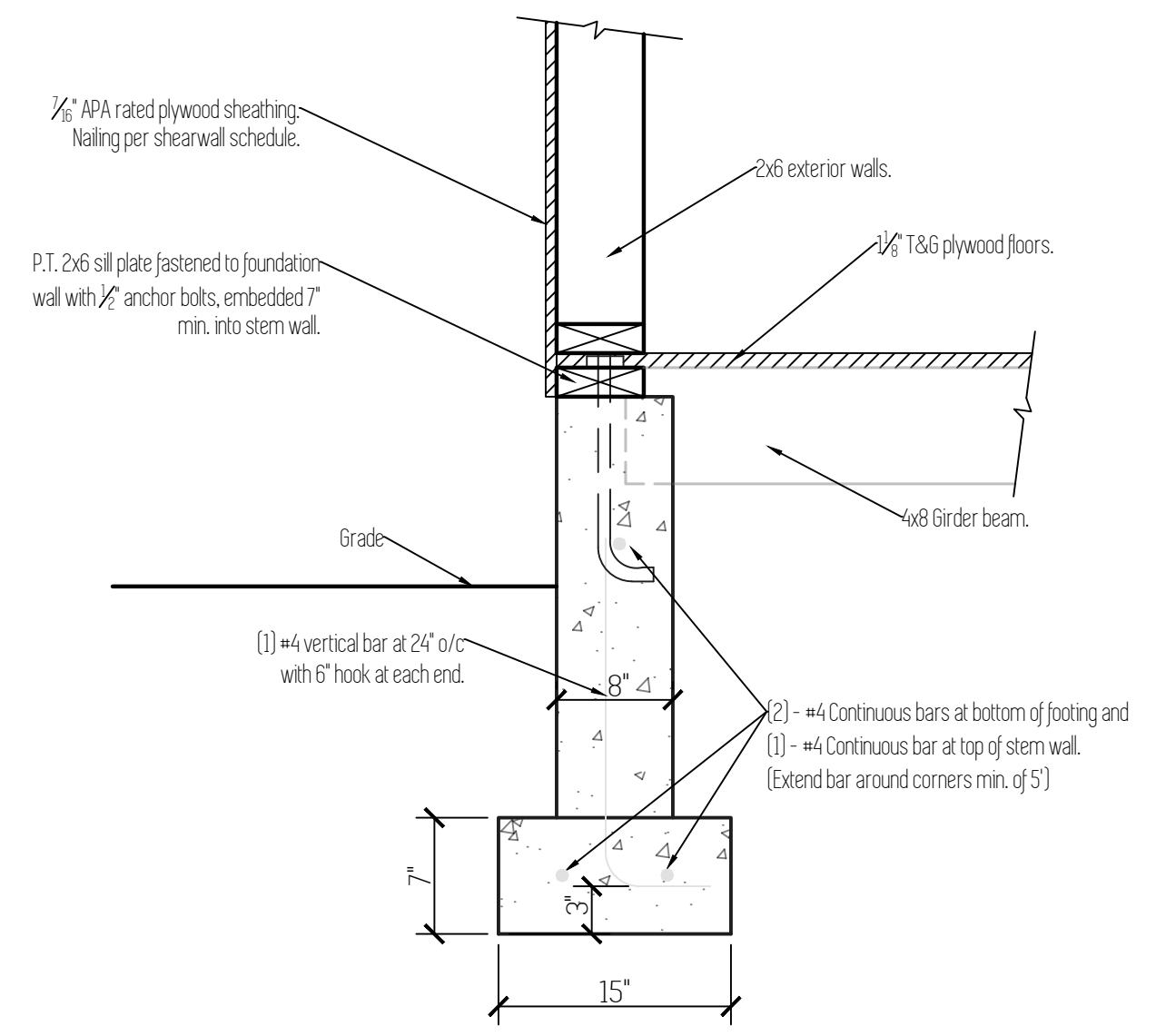
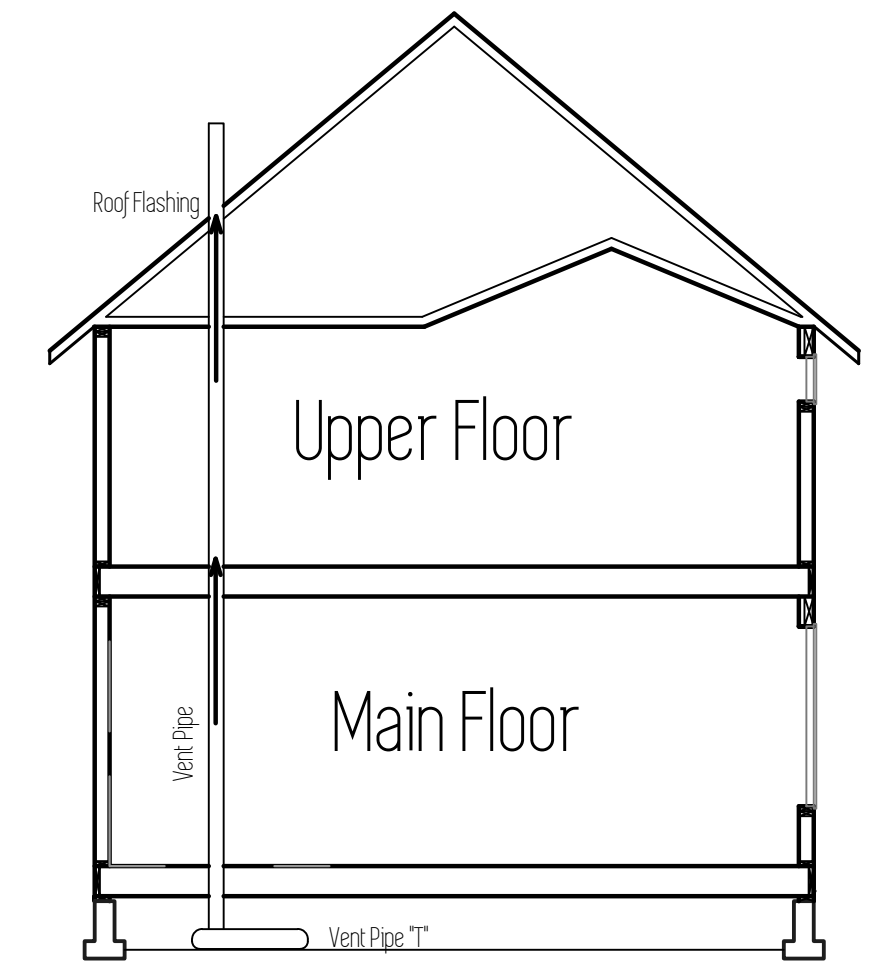

Typ. Foundation Wall
Scale: 1"=1'

Note:
1. Footing to be place on undisturbed, native soil.

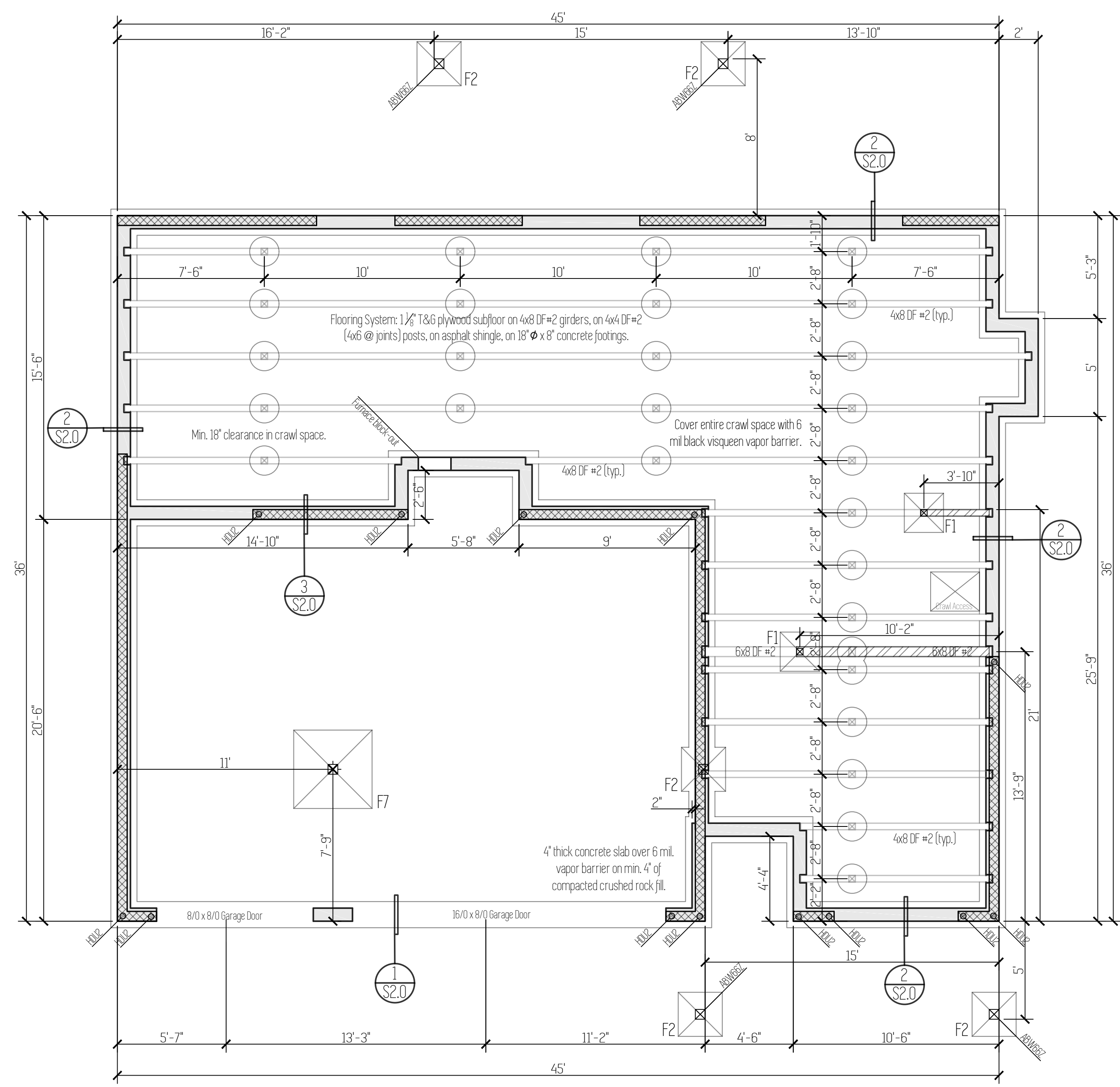

Foundation Plan & Lower Floor Framing

Plan Name	Wahkeena B
Date	1/7/2019
Location	Lone Oak Estates Lot 125 Battle Ground, WA

Total Sq Ft = 2,110

Framing Plan

Scale: 1/4" = 1'

This plan is property of:

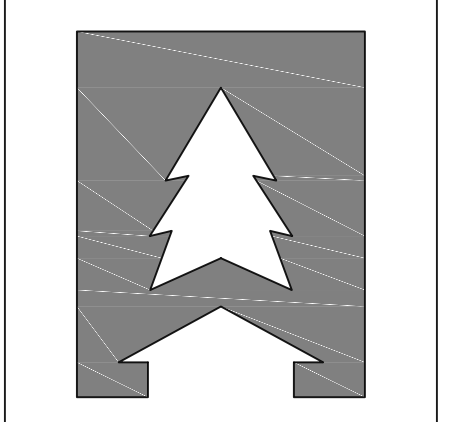

**CEDARRIDGE
HOMES**

© 2019 Cedar Ridge Homes
(P) 503-666-4240
(F) 503-666-2408
www.cedarridgehomes.us

Designed by:
TYSON GREY
tyson@cedarridgehomes.us

5

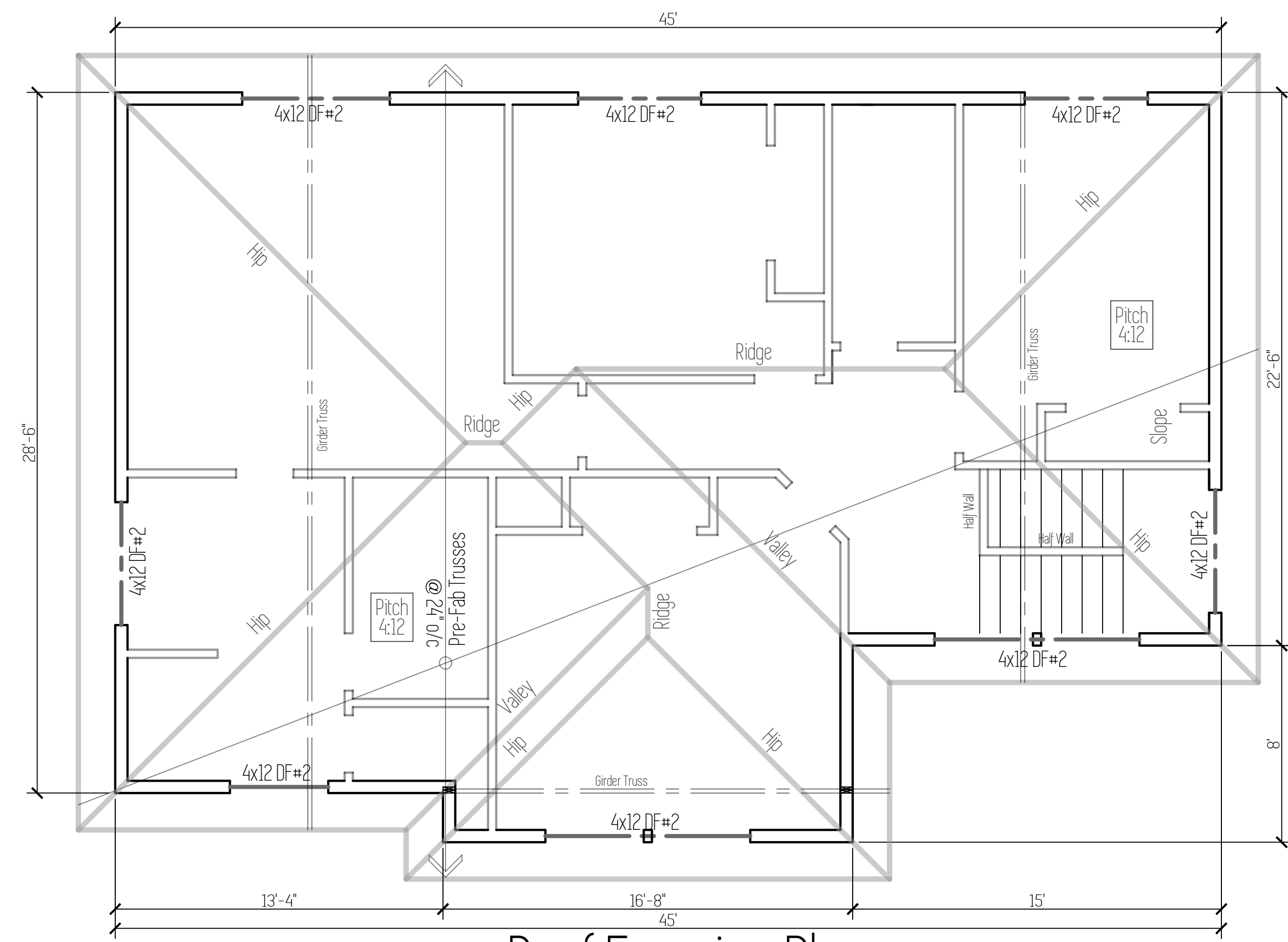

Roof Framing Plan

1. Refer to sheet S1.0 for details on Shear Panels and Strapping.
2. Exterior Headers to be 4x8 DF#2 (max. span 6') U.N.O.
3. Interior Headers to be 4x8 DF#2 (max. span 4') U.N.O.
4. Typical exterior wall post to be (2)-2x6 DF#2 (bundled stud), fasten each stud together w/16d nails @ 12" o/c, typ. entire length of stud, u.n.o. Typical interior wall post to be (2)-2x4 DF#2 (bundled stud), fasten each stud together w/16d nails @ 12" o/c, typ. entire length of stud, u.n.o.
5. Exterior post caps to be Simpson "PC" or "EPC", if exposed condition coat per manufacture's specs with exterior exposed and P.T. material.
6. Roof Overhangs: Hipped roofs, 18" Overhang everywhere.
7. Install 8" roof vents at 4' o/c along ridge.

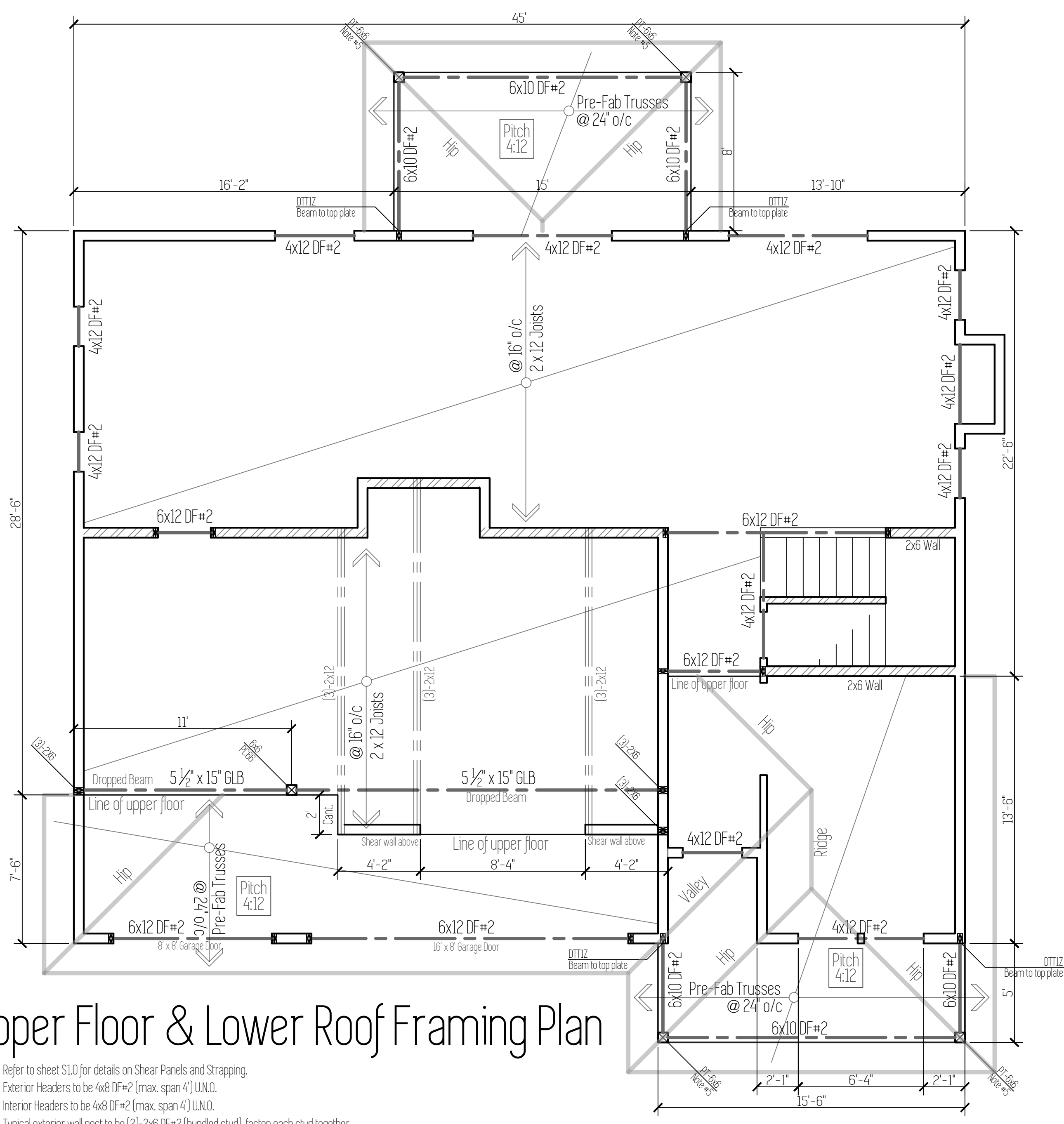
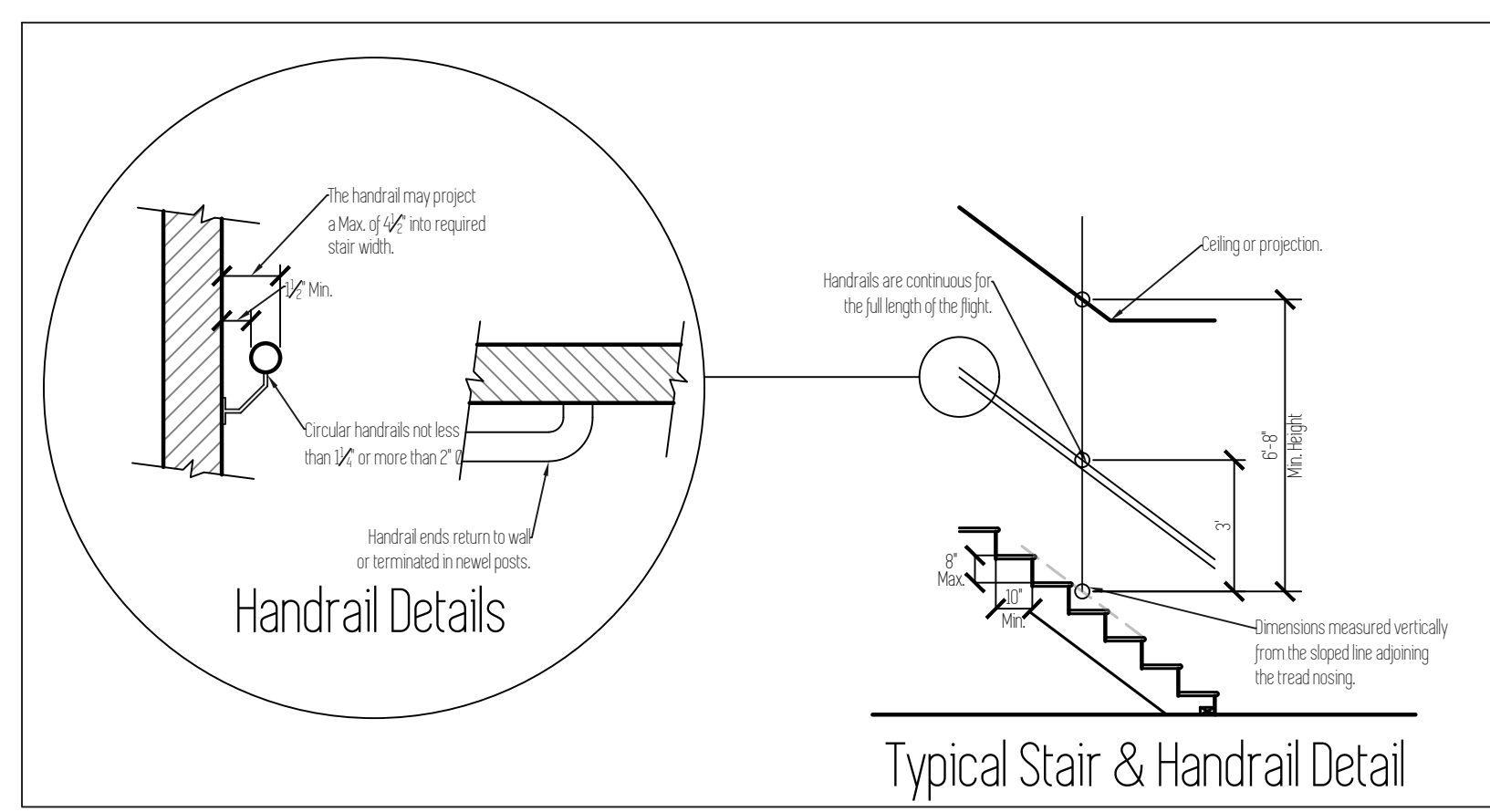

Upper Floor & Lower Roof Framing Plan

1. Refer to sheet S1.0 for details on Shear Panels and Strapping.
 2. Exterior Headers to be 4x8 DF#2 (max. span 4') U.N.O.
 3. Interior Headers to be 4x8 DF#2 (max. span 4') U.N.O.
 4. Typical exterior wall post to be (2)-2x6 DF#2 (bundled stud), fasten each stud together w/16d nails @ 12" o/c, typ. entire length of stud, u.n.o. Typical interior wall post to be (2)-2x4 DF#2 (bundled stud), fasten each stud together w/16d nails @ 12" o/c, typ. entire length of stud, u.n.o.
 5. Exterior post caps to be Simpson "PC" or "EPC", if exposed condition coat per manufacture's specs with exterior exposed and P.T. material.
 6. Roof Overhangs: Hipped roofs, 18" Overhang everywhere.
 7. Install 8" roof vents at 4' o/c along ridge.
- ▨ Interior Bearing Wall

Plan Name	Wahkeena B
Date	1/7/2019
Location	Lone Oak Estates Lot 125 Battle Ground, WA

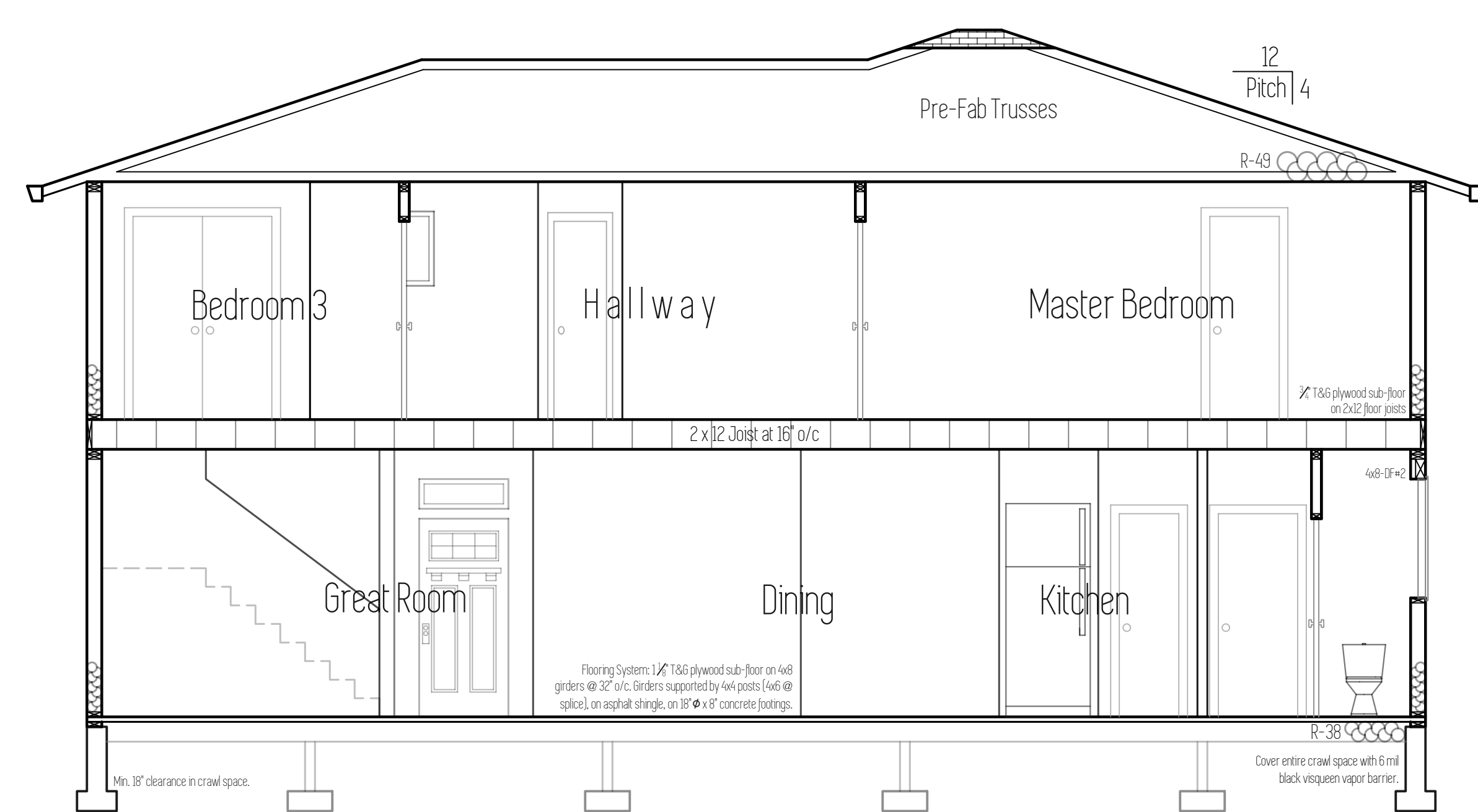

Section B

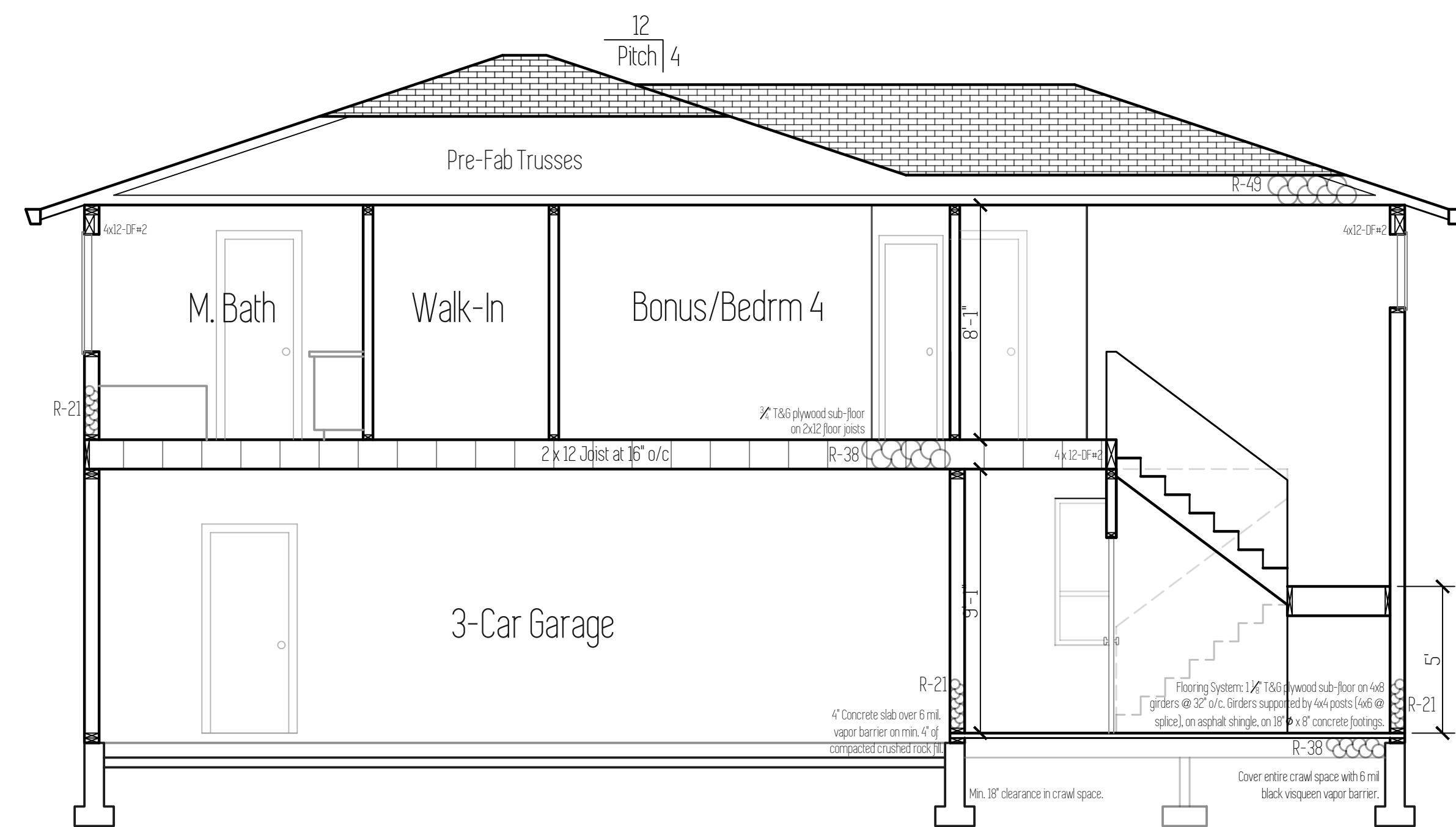

Section A

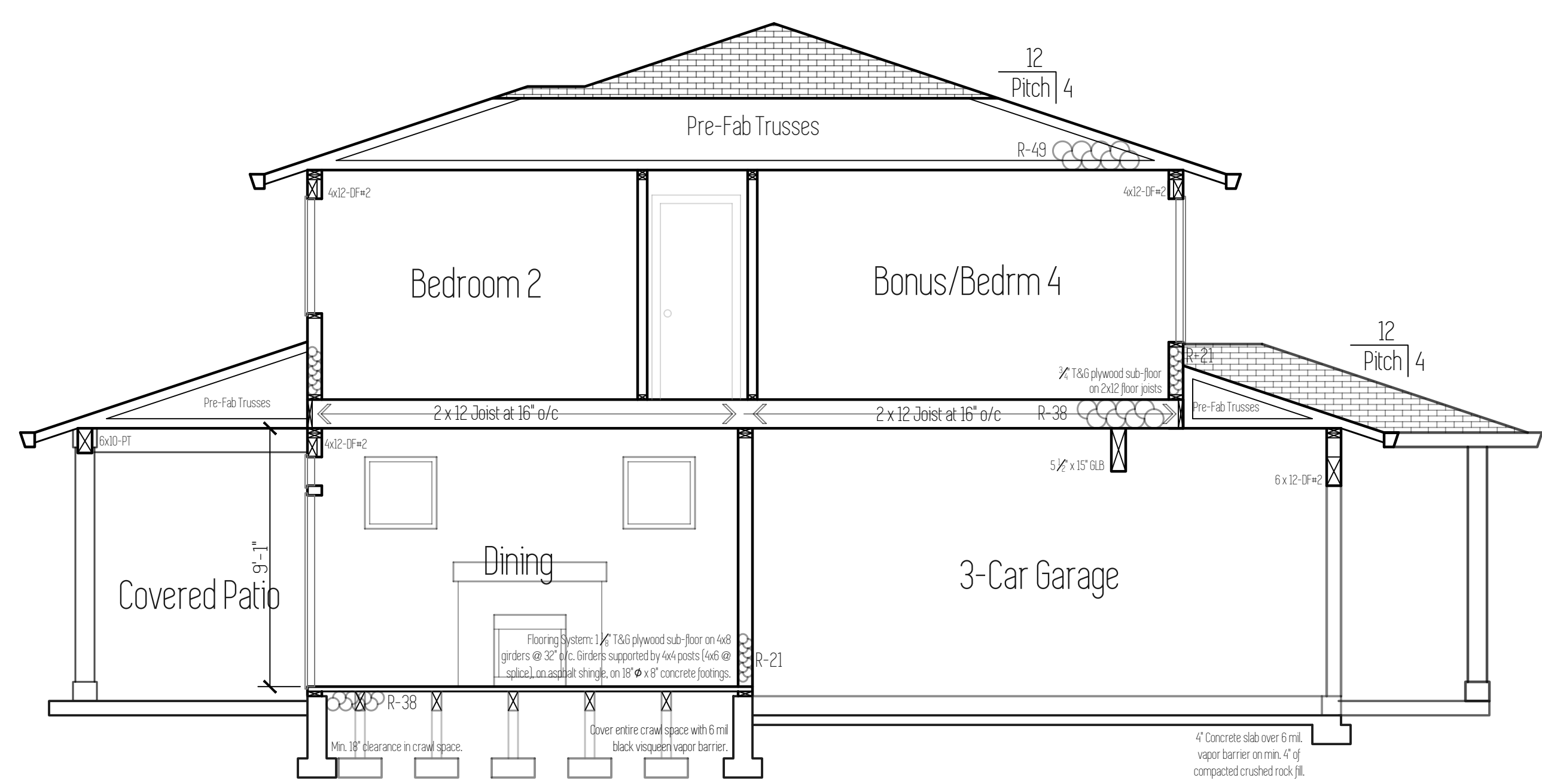

Section D

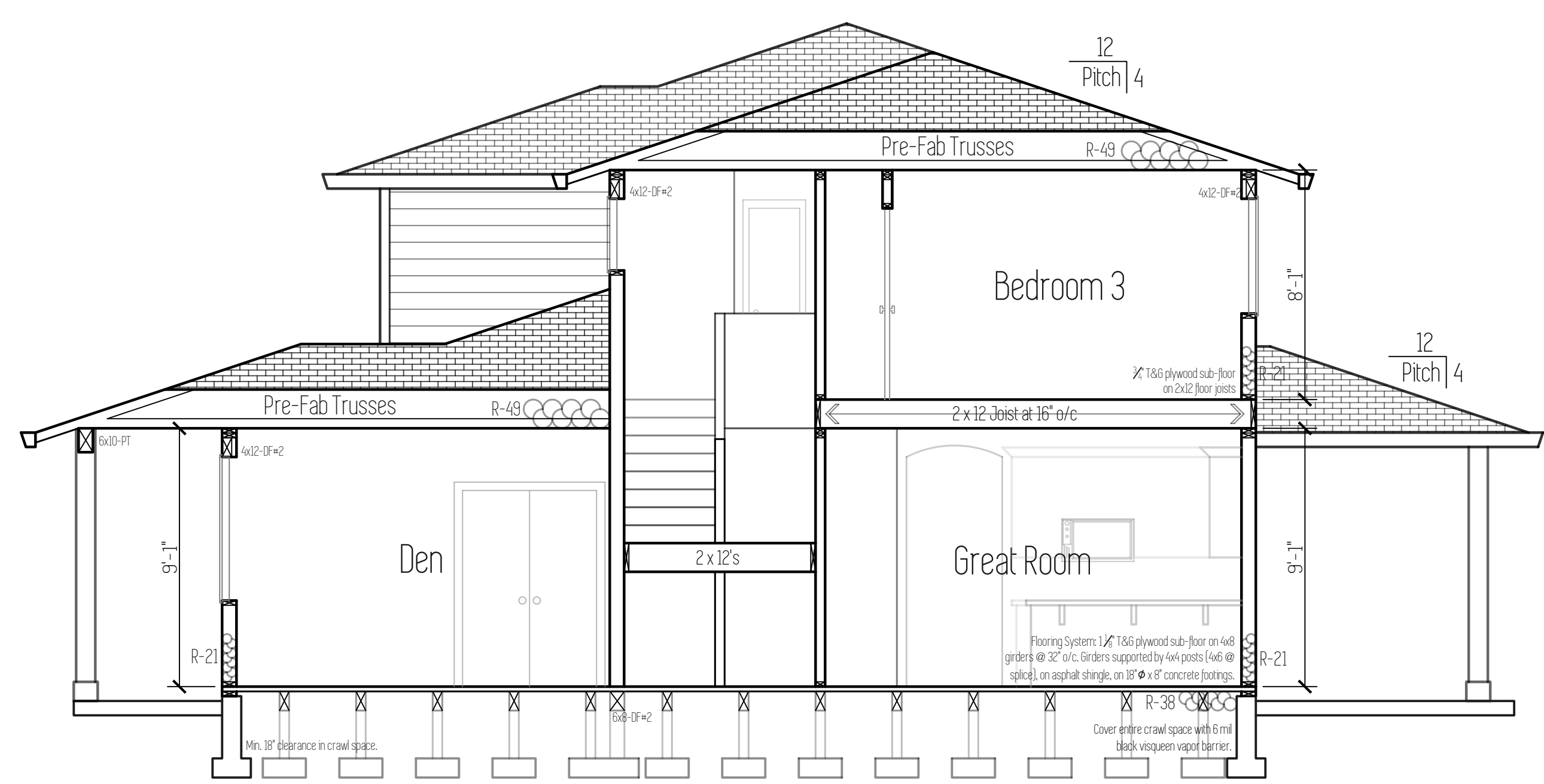

Section C

Total Sq Ft = 2,110

Sections

Scale: 1/4" = 1'

This plan is property of:

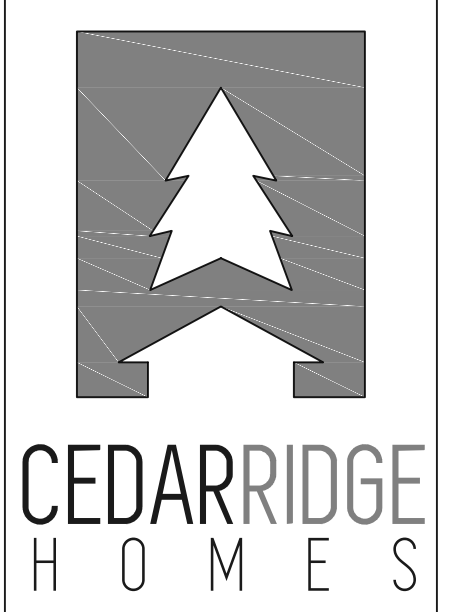

© 2019 Cedar Ridge Homes
(P) 503-666-4240
(F) 503-666-2408
www.cedarridgehomes.us

Designed by:
TYSON GREY
tyson@cedarridgehomes.us

SUMMARY OF WORK:

LOCATION: LOE 125 BATTLE GROUND, WASHINGTON
STRUCTURAL ANALYSIS AND DESIGN FOR SINGLE FAMILY RESIDENCE

DESIGN LOADS:

CODE: 2015 IBC
USE OR OCCUPANCY OF BUILDINGS AND STRUCTURES RISK CATEGORY (ASCE TABLE 1.5-1): II
WIND SPEED Valt: 135 MPH EXPOSURE 'B', Vasd = 105 MPH (OSCC EQUATION 16-33)
SEISMIC DESIGN CATEGORY: 'D'
GROUND SNOW LOAD: 25 PSF (ROOF SNOW LOAD: 25 PSF)
ROOF DEAD LOAD: 15 PSF
FLOOR LIVE LOAD: 40 PSF
FLOOR DEAD LOAD: 10 PSF
SOIL BEARING PRESSURE: 1500 PSF
SOIL PASSIVE SOIL PRESSURE: 200 PSF

FRAMING REQUIREMENTS:

- WALL STUDS TO BE 2X6 DFL-#2 @ 16" O.C., TYPICAL U.N.O.
- ROOF SHEATHING TO BE 1/2" APA RATED CDX SHEATHING OR OSB. INSTALL PANELS HORIZONTALLY. SPACE 8d NAILS MAXIMUM 6" O.C. ALONG PANEL EDGES. FOR OTHER CONDITIONS, SPACE 8d NAILS MAXIMUM 12" O.C. ON INTERMEDIATE SUPPORTS.
- TYPICAL WALL SHEATHING (TS) TO BE 1/2" APA RATED CDX SHEATHING OR OSB. ALL PANEL EDGES TO BE BACKED WITH 2-INCH NOMINAL OR WIDER FRAMING. INSTALL PANELS HORIZONTALLY OR VERTICALLY. SPACE 8d NAILS MAXIMUM 6" O.C. ALONG PANEL EDGES. FOR OTHER CONDITIONS AND PANEL THICKNESSES, SPACE 8d NAILS MAXIMUM 12" O.C. ON INTERMEDIATE SUPPORTS.
- FLOOR SHEATHING TO BE 1/2" APA RATED CDX SHEATHING OR OSB. SPACE 8d NAILS MAXIMUM 6" O.C. ALONG PANEL EDGES. FOR OTHER CONDITIONS, SPACE 8d NAILS MAXIMUM 12" O.C. ON INTERMEDIATE SUPPORTS.
- SILL PLATE TO BE 2X P.T. U.N.O. (REFER TO SILL BOLT SPACING IN SCHEDULE BELOW).
- FOR NAIL SIZES REFER TO BELOW.

SHEAR WALL SCHEDULE: (1) (2) (4)						
PANEL NOTATION	SHEATHING THICKNESS (IN.)	NAILS/SPACING	DBL. STUD CONN. (FACE NAIL)	SILL BOLT ⁽⁵⁾ SPACING	SHEAR CAPACITY (SEISMIC)	SHEAR CAPACITY (WIND)
D6	1 1/2"	8d @ 6" O/C	16d @ 9" O/C	1/2" Ø @ 36" O/C	260 PLF	365 PLF
D4	1 1/2"	8d @ 4" O/C	16d @ 6" O/C	1/2" Ø @ 24" O/C	380 PLF	532 PLF
D3	1 1/2"	8d @ 3" O/C	16d @ 4" O/C	1/2" Ø @ 18" O/C	490 PLF	685 PLF
D2	1 1/2"	8d @ 2" O/C	16d @ 3" O/C	1/2" Ø @ 16" O/C	640 PLF	895 PLF
E2	1 1/2"	10d @ 2" O/C	N/A	1/2" Ø @ 14" O/C	770 PLF	1077 PLF

NOTES:
(1) SHEATHING TO BE APA RATED SHEATHING OR OSB (GRADE C-C OR C-D STRUCTURAL II OR BETTER).
(2) ALL PANEL EDGES TO BE BACKED WITH 2-INCH NOMINAL OR WIDER FRAMING (DFL-#2). INSTALL PANELS EITHER HORIZONTALLY OR VERTICALLY. SPACE NAILS MAXIMUM 6" O.C. ALONG PANEL EDGES FOR STUDS SPACED 24" O.C. FOR OTHER CONDITIONS AND PANEL THICKNESSES, SPACE NAILS MAXIMUM 12" O.C. ON INTERMEDIATE SUPPORTS.
(3) FRAMING AT ADJOINING PANEL EDGES SHALL BE A SINGLE 3" NOMINAL MEMBER OR 2" 2-INCH NOMINAL MEMBER FASTENED TOGETHER WITH 16d NAILS (SPACING ABOVE) TYPICAL ENTIRE HEIGHT OF DBL. STUD. NAILS SHALL BE STAGGERED WHERE NAILS ARE SPACED 2" O.C.
(4) AT SHEAR WALL LOCATIONS REFER TO (1) AND (2) FOR ROOF TO WALL AND FLOOR TO FLOOR FRAMING.
(5) INSTALL 3" SQUARE X 1/2" STEEL PLATE WASHER.
(6) FRAMING AT ADJOINING PANEL EDGES SHALL BE SINGLE 2X NOMINAL FRAMING MEMBERS AT EACH END OF THE PANEL. NAILS SHALL BE STAGGERED WHERE NAILS ARE SPACED 2" O.C. INSTALL MIN. 3X P.T. SILL PLATE, U.N.O.
(7) GALVANIZED NAILS SHALL BE HOT-DIPPED OR TUMBLE.
(8) IF 1/2" NOMINAL THICK PLYWOOD OR OSB IS USED, STUDS TO BE SPACED AT 1'-4" O.C. TYPICAL.

HOLD-DOWN SCHEDULE: (2) (3) (4)

HOLD-DOWN NOTATION	'SIMPSON' HOLD-DOWN TYPE	INSTALLATION INSTRUCTIONS
2	HDU2 (3075#)	STD. SB 1/2" X 24" MIN. 18" EMBEDMENT (6) CONCRETE. ANCHOR TO BE INSTALLED PLUMB AND LOCATED ALONG CENTER LINE OF (2)X26 DFL-#2 WALL STUDS (MIN. 2X' EDGE DISTANCE). FASTEN STUDS TOGETHER WITH 16d NAILS @ 6" O/C ENTIRE HEIGHT OF STUD. INSTALL HOLD-DOWN PER MANUFACTURER'S SPECIFICATIONS.
4	HDU4 (4565#)	STD. SB 1/2" X 24" MIN. 18" EMBEDMENT (6) CONCRETE. ANCHOR TO BE INSTALLED PLUMB AND LOCATED ALONG CENTER LINE OF (2)X26 DFL-#2 WALL STUDS (MIN. 2X' EDGE DISTANCE). FASTEN STUDS TOGETHER WITH 16d NAILS @ 6" O/C ENTIRE HEIGHT OF STUD. INSTALL HOLD-DOWN PER MANUFACTURER'S SPECIFICATIONS.
5	HDU5 (5645#)	STD. SB 1/2" X 24" MIN. 18" EMBEDMENT (6) CONCRETE. ANCHOR TO BE INSTALLED PLUMB AND LOCATED ALONG CENTER LINE OF (2)X26 DFL-#2 WALL STUDS (MIN. 2X' EDGE DISTANCE). FASTEN STUDS TOGETHER WITH 16d NAILS @ 6" O/C ENTIRE HEIGHT OF STUD. INSTALL HOLD-DOWN PER MANUFACTURER'S SPECIFICATIONS.
8	HDU8 (5980#, 6970#, 7870#)	STD. SB 1/2" X 24" MIN. 18" EMBEDMENT (6) CONCRETE. ANCHOR TO BE INSTALLED PLUMB AND LOCATED ALONG CENTER LINE OF (2)X26 DFL-#2 WALL STUDS (MIN. 2X' EDGE DISTANCE). FASTEN STUDS TOGETHER WITH 16d NAILS @ 6" O/C ENTIRE HEIGHT OF STUD. INSTALL HOLD-DOWN PER MANUFACTURER'S SPECIFICATIONS.
28	MSTC28	INSTALL STRAP ACROSS FLOOR LINE. INSTALL MIN. (8) 16d NAILS INTO DOUBLE WALL STUDS ABOVE FLOOR AND INTO DOUBLE WALL STUDS BELOW. CENTER STRAP ON STUDS TO INSTALL NAILS INTO MIDDLE THIRD OF STUD.
40	MSTC40	INSTALL STRAP ACROSS FLOOR LINE. INSTALL MIN. (16) 16d NAILS INTO DOUBLE WALL STUDS ABOVE FLOOR AND INTO DOUBLE WALL STUDS BELOW. CENTER STRAP ON STUDS TO INSTALL NAILS INTO MIDDLE THIRD OF STUD.

NOTES:
(1) IN LIEU OF SIMPSON 'SSTB' BOLTS ANCHOR BOLTS TO BE A307 OR A306 THREADED ROD WITH STD. NUT AND 2" X 2" X 1/2" STEEL PLATE WASHER ON BOTTOM OF BOLT.
(2) HOLD-DOWNS TO BE FASTENED TO DOUBLE STUDS (CONTINUOUS FROM SILL PLATE TO DOUBLE TOP PLATE) AT PANEL ENDS. WALL STUDS SHOULD HAVE PANEL EDGE NAILING FROM SHEAR WALL SHEATHING.
(3) IF HOLD-DOWNS 2, 5, 6, AND 8 ARE INSTALLED FROM FLOOR TO FLOOR, REFER TO DETAIL FF S1.
(4) U.N.O. INSTALL (1) #4 CONTINUOUS HORIZONTAL TOP BAR 3" DOWN FROM TOP OF WALL AT ALL HOLD-DOWN ANCHORS. EXTEND BAR MIN. 5'-0" PAST HOLD-DOWN IN BOTH DIRECTIONS (BEND BAR AROUND AT CORNER CONDITION). FOR THIS 10'-0" SECTION INSTALL (1) #4 VERTICAL BAR @ 24" O.C. THE HOLD-DOWN ANCHOR TO HORIZONTAL TOP BAR.

SHEAR WALL / HOLD-DOWN NOTATION DIAGRAM

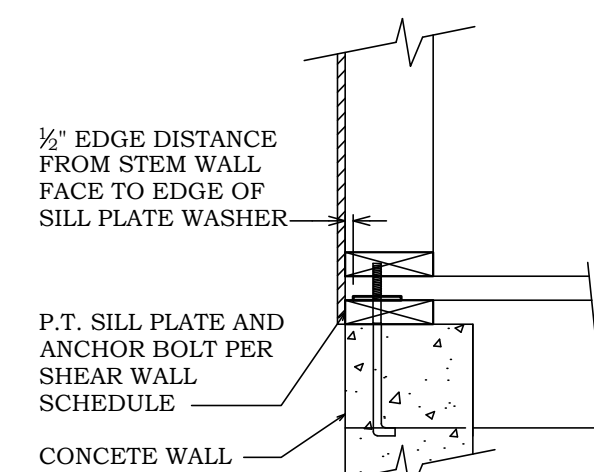
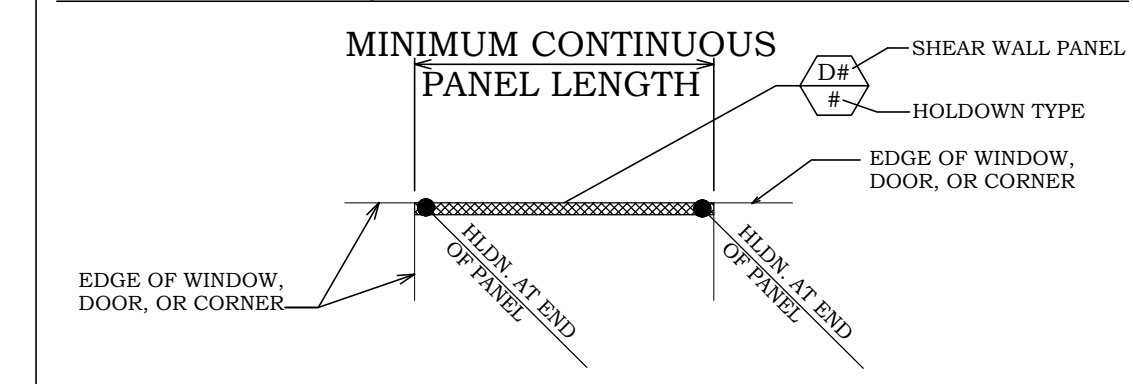

FSP FDN. SILL PLATE SECTION
S1

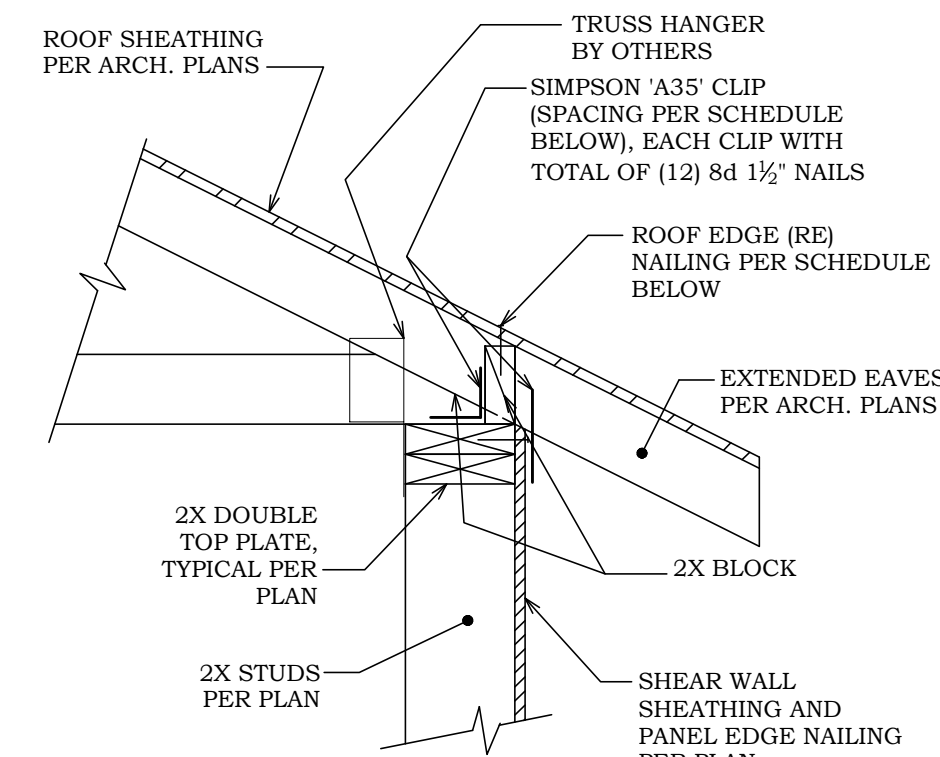

RW ROOF TO SHEAR WALL SECTION
S1

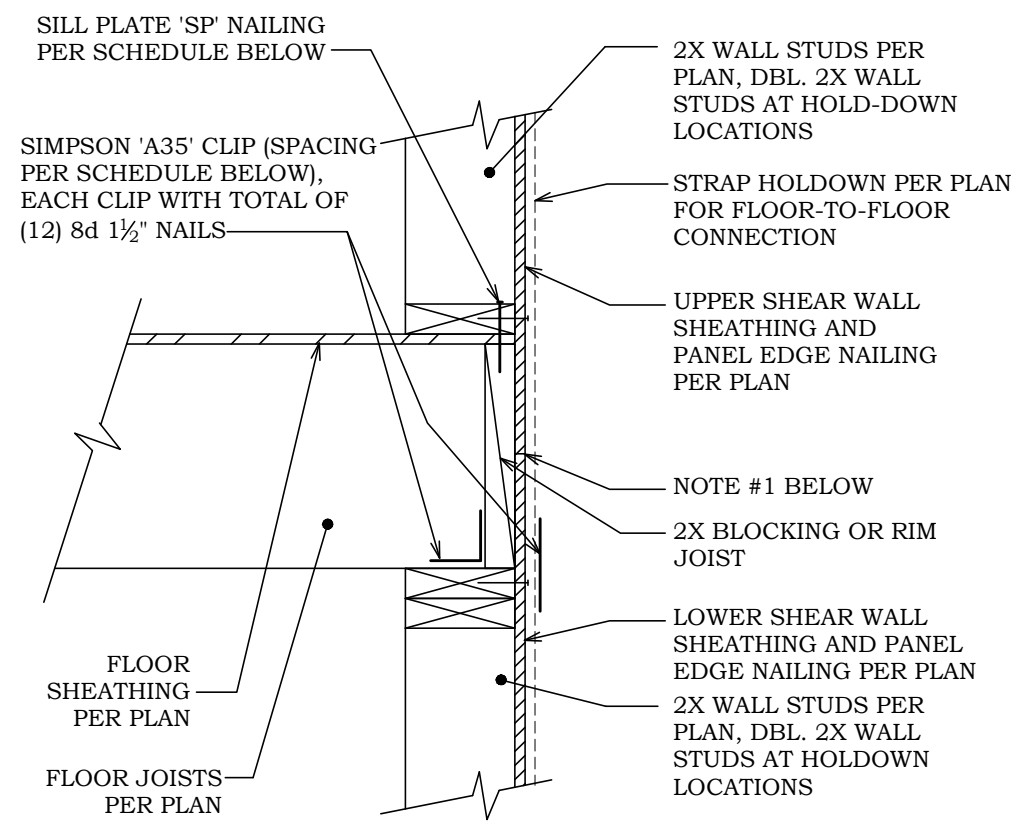

FF FLOOR TO FLOOR SECTION AT SHEAR WALL
S1

PANEL TYPE	'SP' NAIL SPACING	SIMPSON CLIP SPACING	'RE' NAIL SPACING
D6	16d @ 8" O.C.	1'-8" O.C.	8d @ 8" O.C.
D4	16d @ 4" O.C.	1'-2" O.C.	8d @ 4" O.C.
D3	16d @ 3" O.C.	0'-11" O.C.	8d @ 3" O.C.
D2	16d @ 3" O.C.	8" O.C.	8d @ 2 1/2" O.C.
E2	16d @ 2" O.C.	7" O.C.	8d @ 2" O.C.

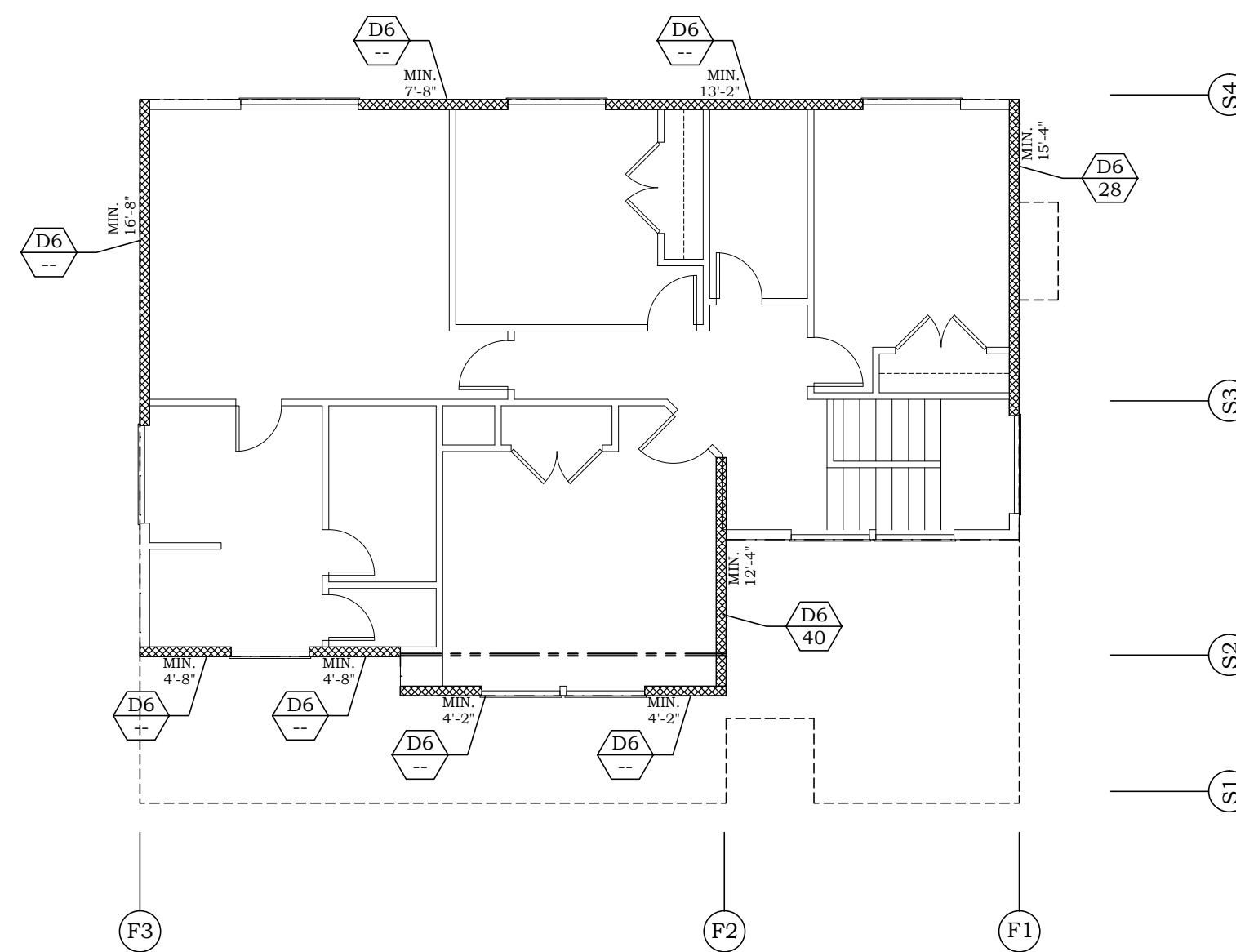

UPPER FLOOR SHEARWALL PLAN

NOTE:
1. REFER TO FRAMING REQUIREMENTS FOR TYPICAL EXTERIOR SHEATHING AND NAILING, ROOF SHEATHING AND NAILING AND FLOOR SHEATHING AND NAILING REQUIREMENTS.

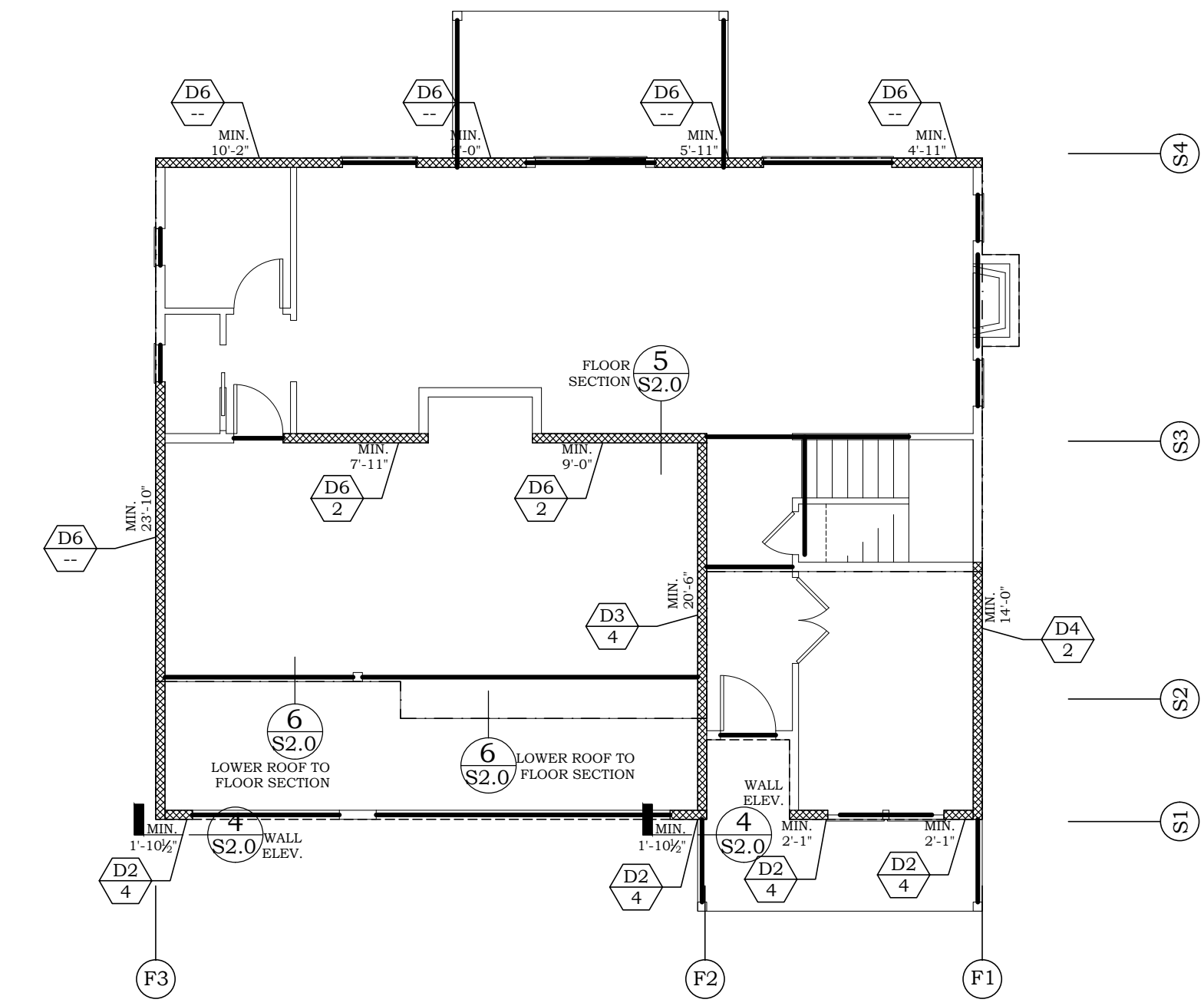

MAIN FLOOR SHEARWALL PLAN

NOTE:
1. REFER TO FRAMING REQUIREMENTS FOR TYPICAL EXTERIOR SHEATHING AND NAILING, ROOF SHEATHING AND NAILING AND FLOOR SHEATHING AND NAILING REQUIREMENTS.

No.	DATE	DESCRIPTION

PROJECT NAME	WAHKEENA RESIDENCE SHEAR WALL AND HOLD-DOWN SCHEDULE SHEAR WALL PLANS
--------------	---

TURNER ENGINEERING & DESIGN
ENGINEERS STAMP
Professional Engineer
No. 11,220
Expires OCT 20, 2019

ISSUE CD
DESIGNED BY RJT
DRAWN BY RJT
CHECKED BY RJT
DATE 04/07/17
PROJECT NO. R17117
SHEET NO. S1.0

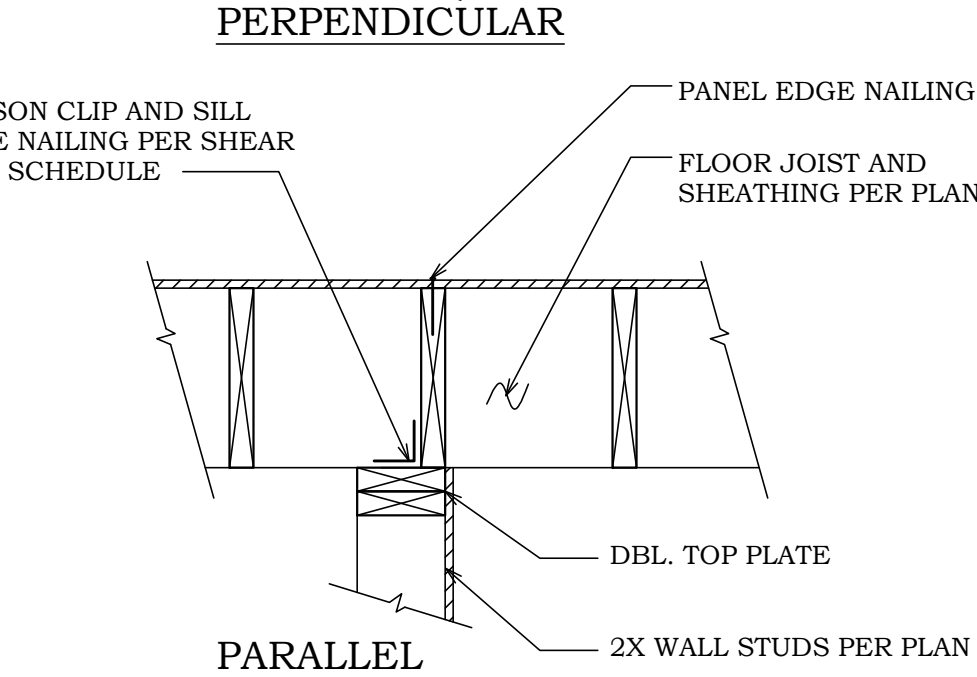
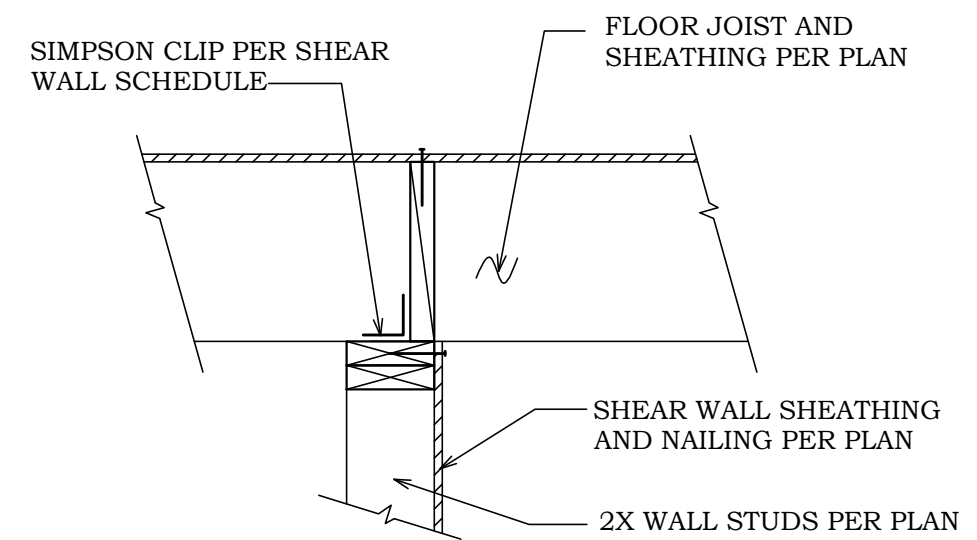

5 WALL SECTION
S2 SCALE: NONE

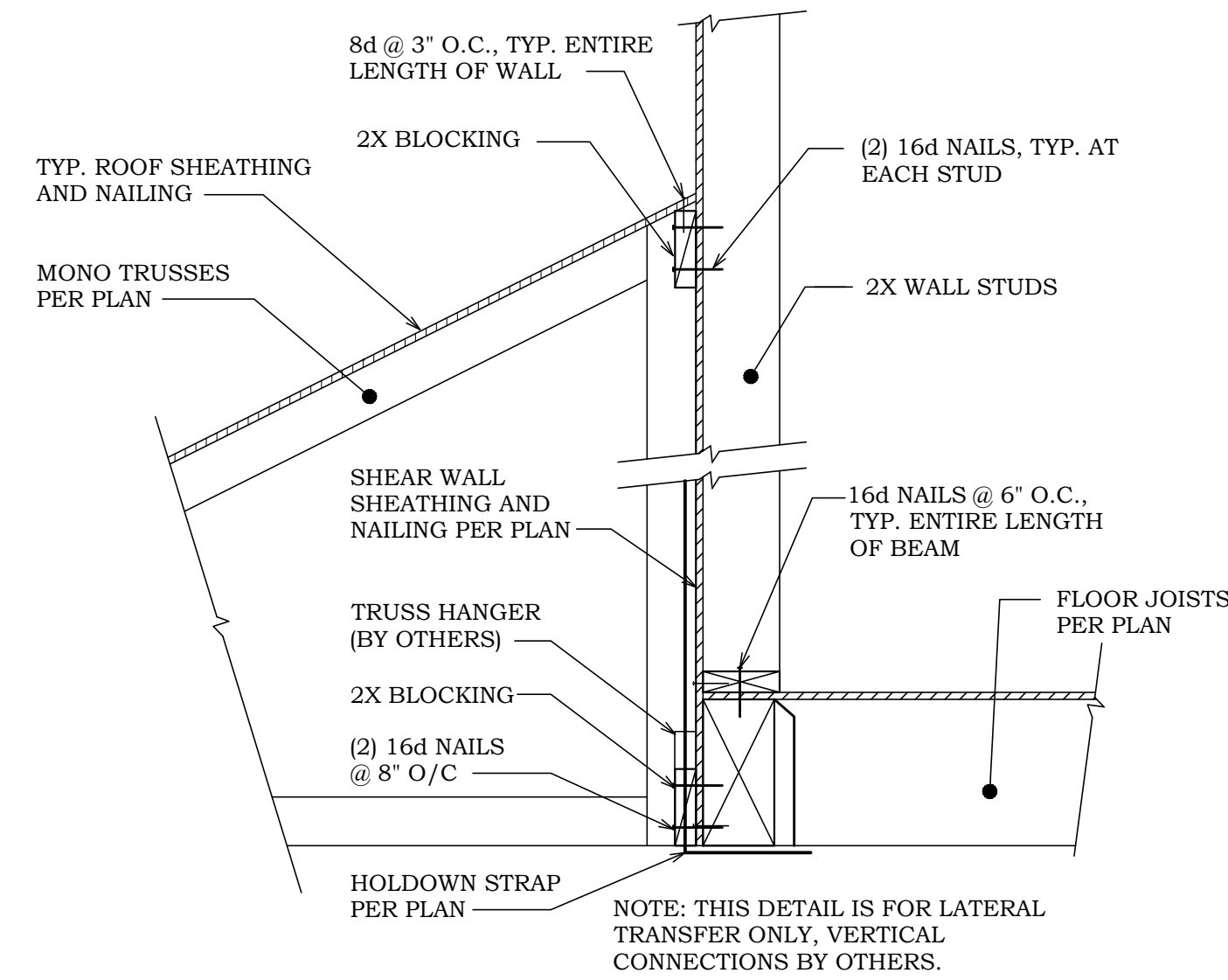

6 LOWER ROOF SECTION
S2.0 SCALE: 1" = 1'-0"

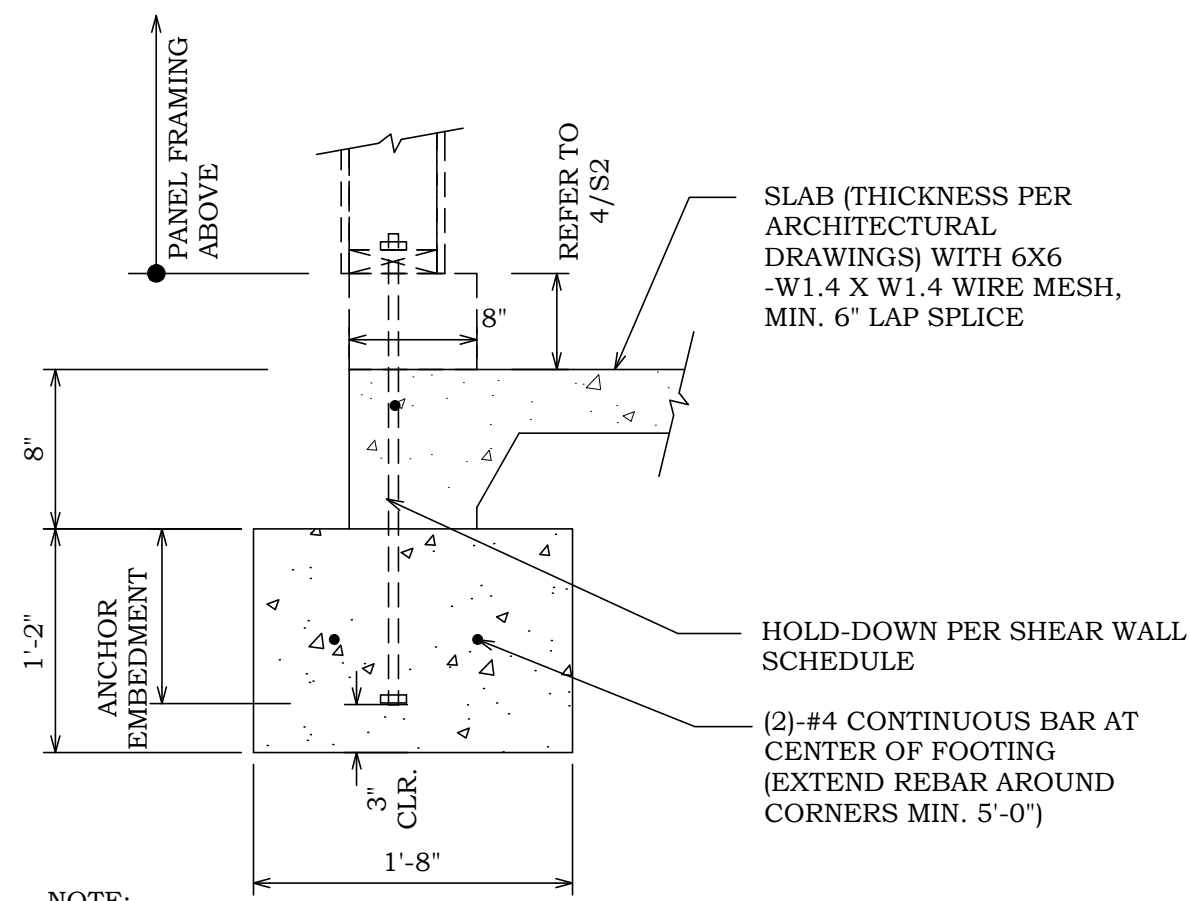

NOTE:
1. FOOTING TO BE PLACED ON UNDISTURBED NATIVE SOIL.
2. DRIVEWAY SURFACE NOT SHOWN.

1 FOOTING SECTION
S2 SCALE: 1" = 1'-0"

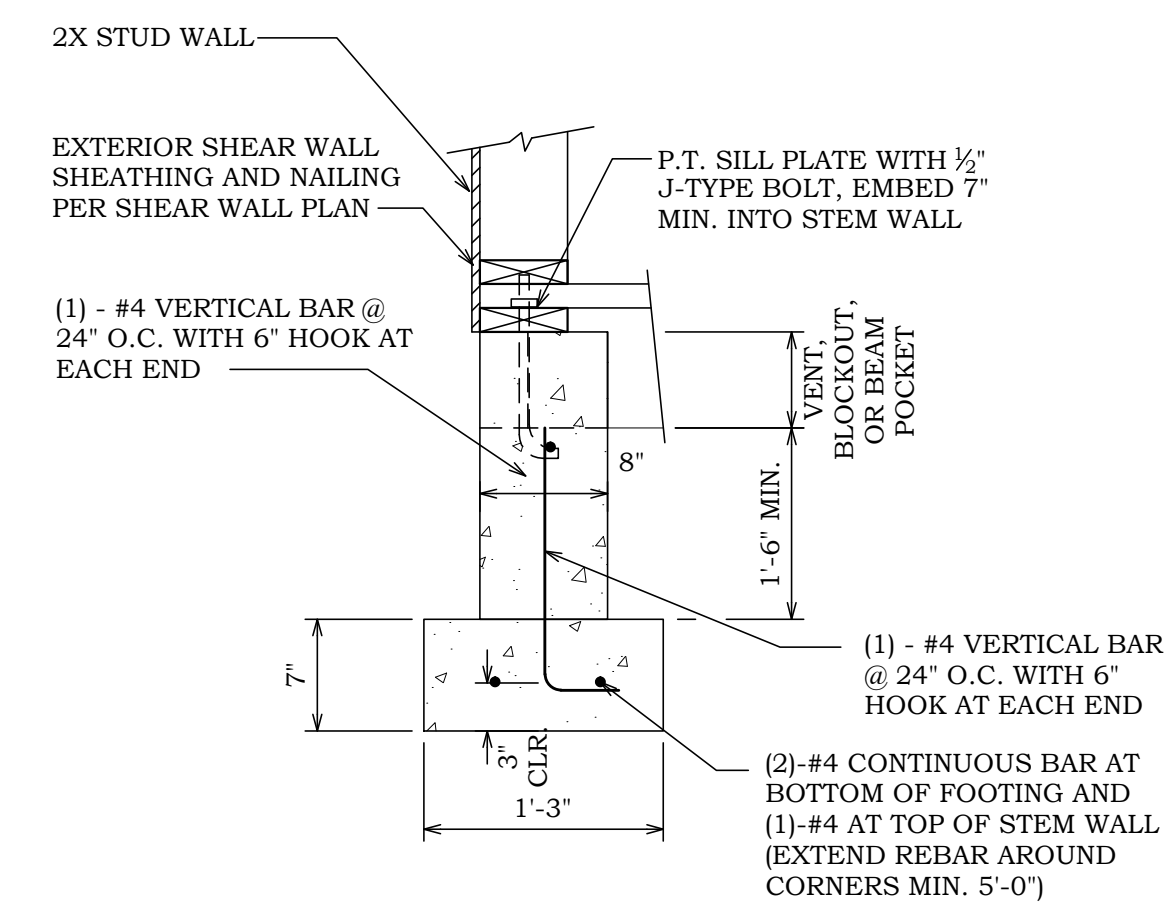

NOTE:
1. FOOTING TO BE PLACED ON UNDISTURBED NATIVE SOIL.
2. REFER TO SHEAR WALL SCHEDULE SILL BOLT SPACING AT SHEAR WALL LOCATIONS.

2 FOOTING SECTION
S2 SCALE: NONE

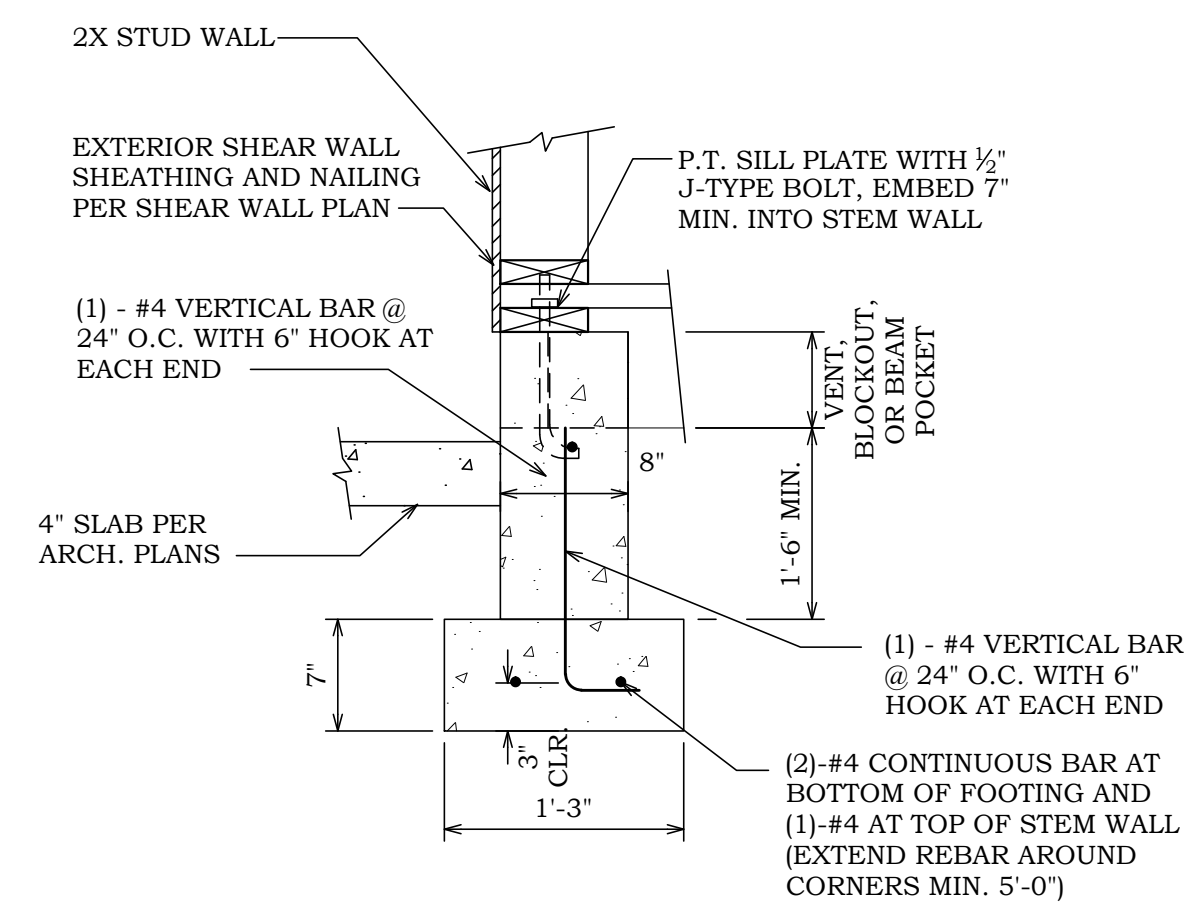

NOTE:
1. FOOTING TO BE PLACED ON UNDISTURBED NATIVE SOIL.
2. REFER TO SHEAR WALL SCHEDULE SILL BOLT SPACING AT SHEAR WALL LOCATIONS.

3 FOOTING SECTION
S2 SCALE: NONE

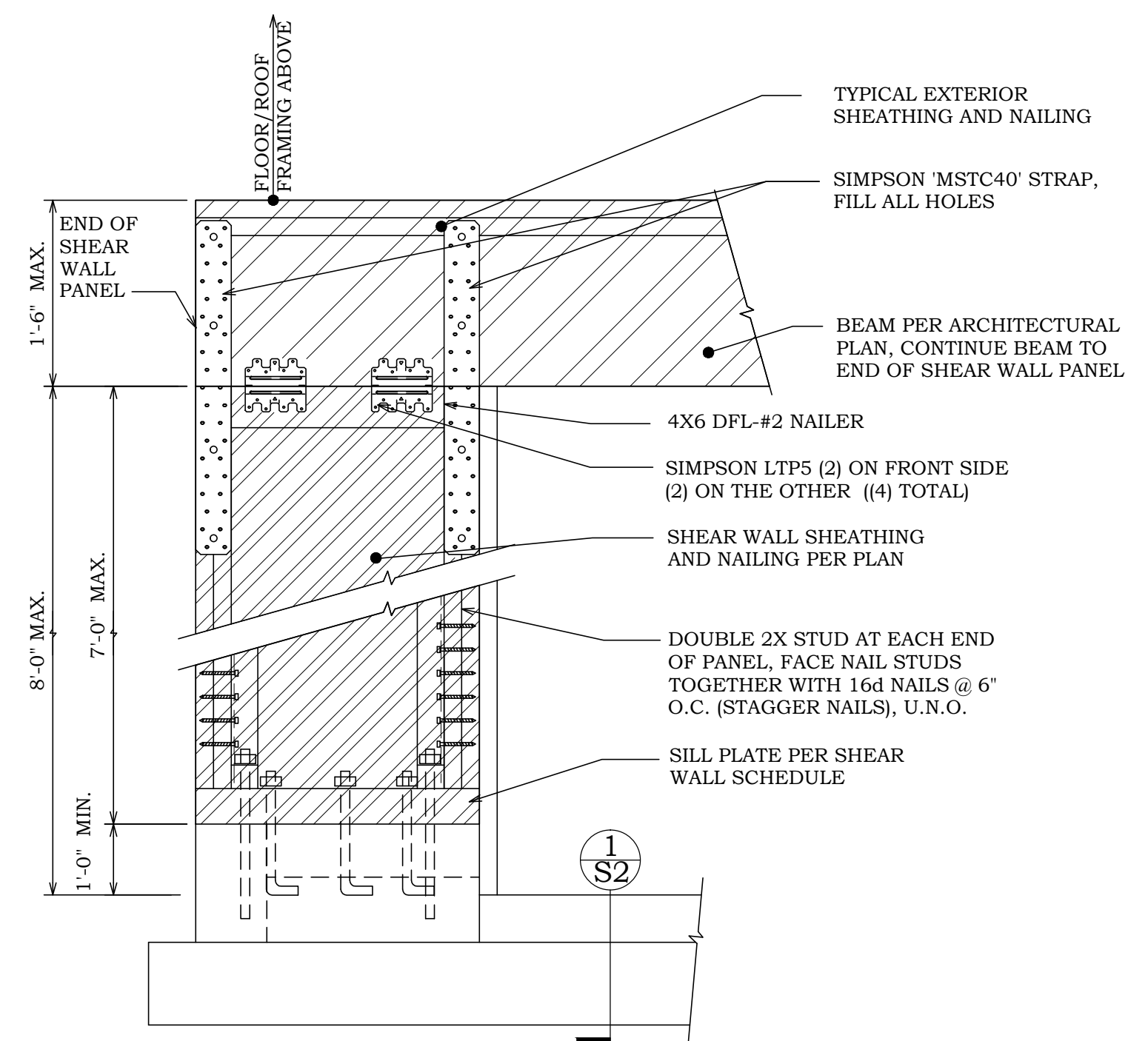

4 SHEAR WALL ELEVATION VIEW
S2 SCALE: NONE

No. DATE DESCRIPTION

PROJECT NAME
LOC 125
STRUCTURAL DETAILS

TURNER
ENGINEERING & DESIGN
Office/Cell: (503) 979-8807
Email: turner_tendesign@gmail.com
11220
EAGLE CREEK, OREGON 97022

ENGINEERS STAMP

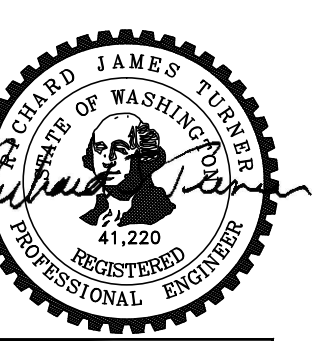

ISSUE CD
DESIGNED BY RJT
DRAWN BY JSF
CHECKED BY RJT
DATE 01/19/19
PROJECT NO. R19041
SHEET NO.

S2.0